



Pallet Stackers

MM10 | ML10

Capacity 1.0 t | Series 1167

PB

Flexible pallet stacker for stillages or open-bottom pallets

- Suitable for stacking, transport and order picking duties
- Adjustable picking height ensures operator comfort
- Long tiller arm, wrap-around tiller and low chassis skirt protects the operator
- Automatic speed reduction in corners increases stability
- Range of mast lift heights suits many different applications
- Mast design ensures good visibility of forks and load

TECHNICAL DATA (according to VDI 2198)

Characteristics	1.1	Manufacturer (abbreviation)		Linde MH	Linde MH	Linde MH
	1.2	Manufacturer's type designation		MM10	MM10i	ML10
	1.2a	Series		1167-02	1167-02	1167-02
	1.3	Drive		Battery	Battery	Battery
	1.4	Operation		Pedestrian	Pedestrian	Pedestrian
	1.5	Rated capacity/rated load	Q (t)	1.0	1.0	1.0
	1.6	Load centre distance	c (mm)	600	600	600
	1.8	Load distance, centre of drive axle to fork	x (mm)	805	805	815
	1.9	Wheelbase	y (mm)	1131	1265	1233
Weight	2.1	Service weight	kg	462	520	605
	2.2	Axle loading, laden front/rear	kg	534/928	580/1140	598/1007
	2.3	Axle loading, unladen front/rear	kg	347/115	370/150	451/154
Tyres/chassis	3.1	Tyres: solid rubber, superelastic, pneumatic, polyurethane		Polyurethane	Polyurethane	Polyurethane
	3.2	Tyre size, front	mm	210x70	210x70	210x70
	3.3	Tyre size, rear	mm	80x60	80x60	80x60
	3.5	Wheels, number front/rear (x = driven wheels)		1x+1/4	1x+1/4	1x+1/4
Dimensions	4.2	Mast height, lowered	h1 (mm)	1940	1940	2070
	4.3	Free lift	h2 (mm)	1505	1480	0
	4.4	Lift	h3 (mm)	1517	1513	2927
	4.5	Mast height, extended	h4 (mm)	1955	2090	3535
	4.6	Initial lift	h5 (mm)	-	115	-
	4.9	Height drawbar in driving position min./max.	h14 (mm)	800/1250	800/1250	800/1250
	4.15	Height, lowered	h13 (mm)	88	88	88
	4.19	Overall length	l1 (mm)	1615	1750	1740
	4.20	Length to fork face	l2 (mm)	465	600	590
	4.21	Overall width	b1/b2 (mm)	800	796	796
	4.22	Fork dimensions DIN ISO 2331	s/e/l (mm)	60/170/1150	60/190/1150	60/170/1150
	4.24	Fork carriage width	b3 (mm)	680	680	680
	4.25	Fork spread	b5 (mm)	550	560	570
	4.32	Ground clearance, centre of wheelbase	m2 (mm)	28	26	28
	4.34.1	Aisle width for pallets 800 × 1200 crossways	Ast (mm)	2229	2392	2225
4.34.2	Aisle width for pallets 800 × 1200 lengthways	Ast (mm)	2100	2260	2150	
4.35	Turning radius	Wa (mm)	1337	1500	1399	
Performance	5.1	Travel speed, laden/unladen	km/h	4.0/4.5	4.0/4.5	4.5/4.8
	5.2	Lifting speed, laden/unladen	m/s	0.10/0.17	0.10/0.14	0.12/0.22
	5.3	Lowering speed, laden/unladen	m/s	0.20/0.13	0.20/0.13	0.20/0.13
	5.8	Max. gradeability, laden/unladen	%	5/15	5/15	5/15
	5.10	Service brake		Electromagnetic	Electromagnetic	Electromagnetic
Electric-engine	6.1	Drive motor rating S2 60 min	kW	0.65	0.65	0.65
	6.2	Lift motor rating at S3 15%	kW	2.2	2.2	2.2
	6.4	Battery voltage/nominal capacity K5	V/Ah	2x12/85	2x12/85	2x12/125
	6.5	Battery weight (±5%)	kg	2x25	2x25	2x33
	6.6	Energy consumption according to DIN EN 16796	kWh/h	0.379	0.456	0.414
	Drive/lifting mechanism	8.1	Type of drive unit		DC control	DC control
Additional data	10.7	Sound pressure level LpAZ (at the operator's seat)	dB (A)	74	74	74

MM10

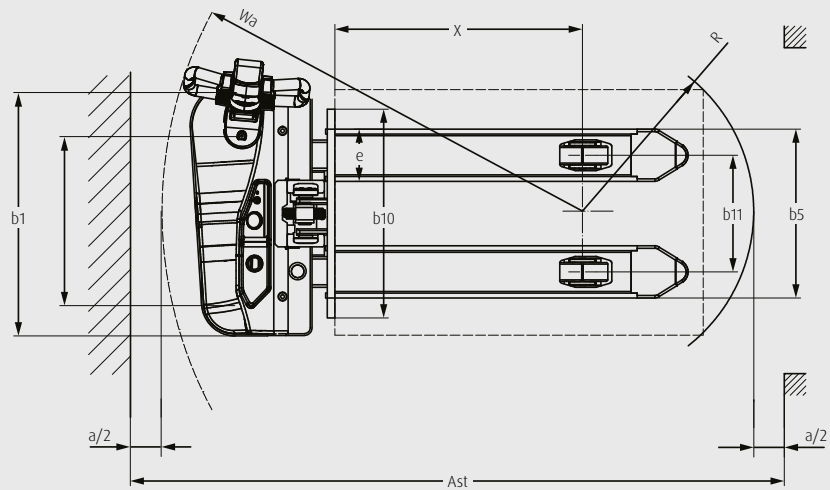
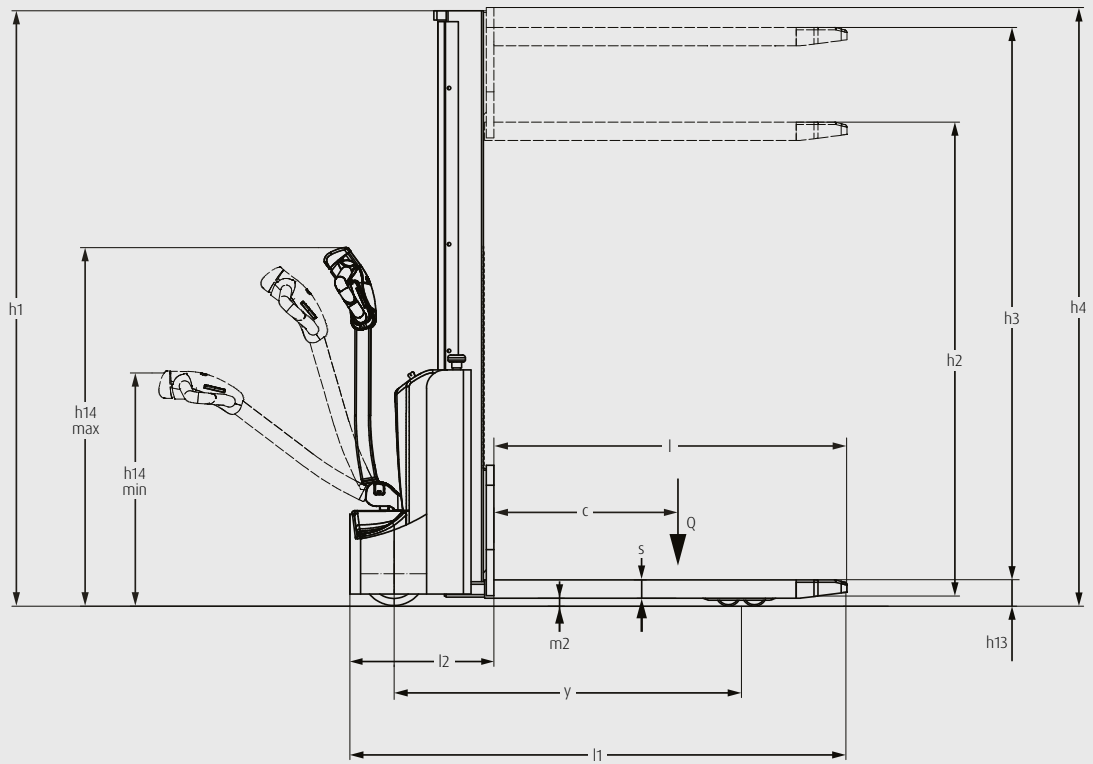

MM10i

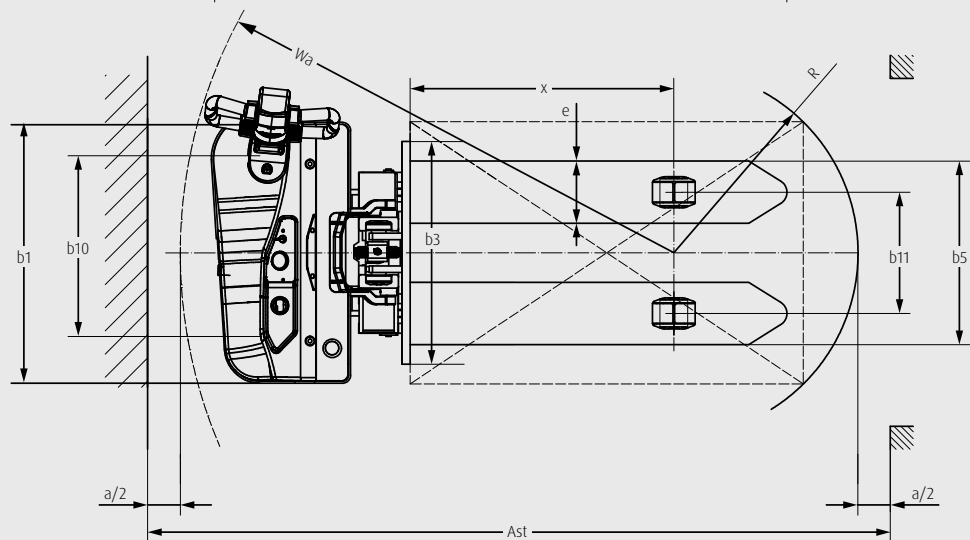
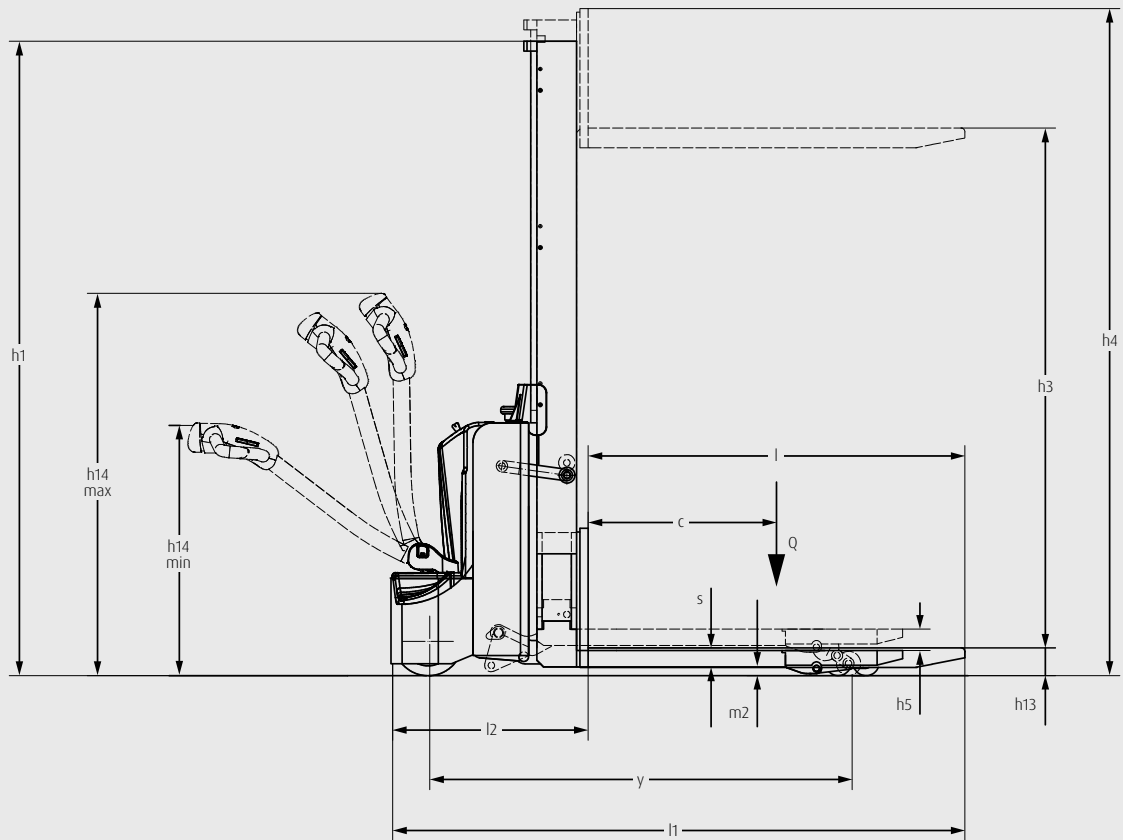

ML10

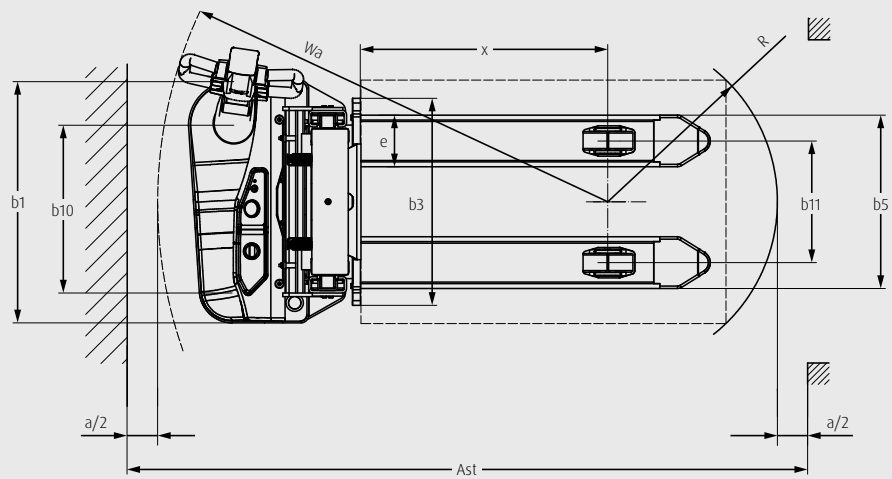
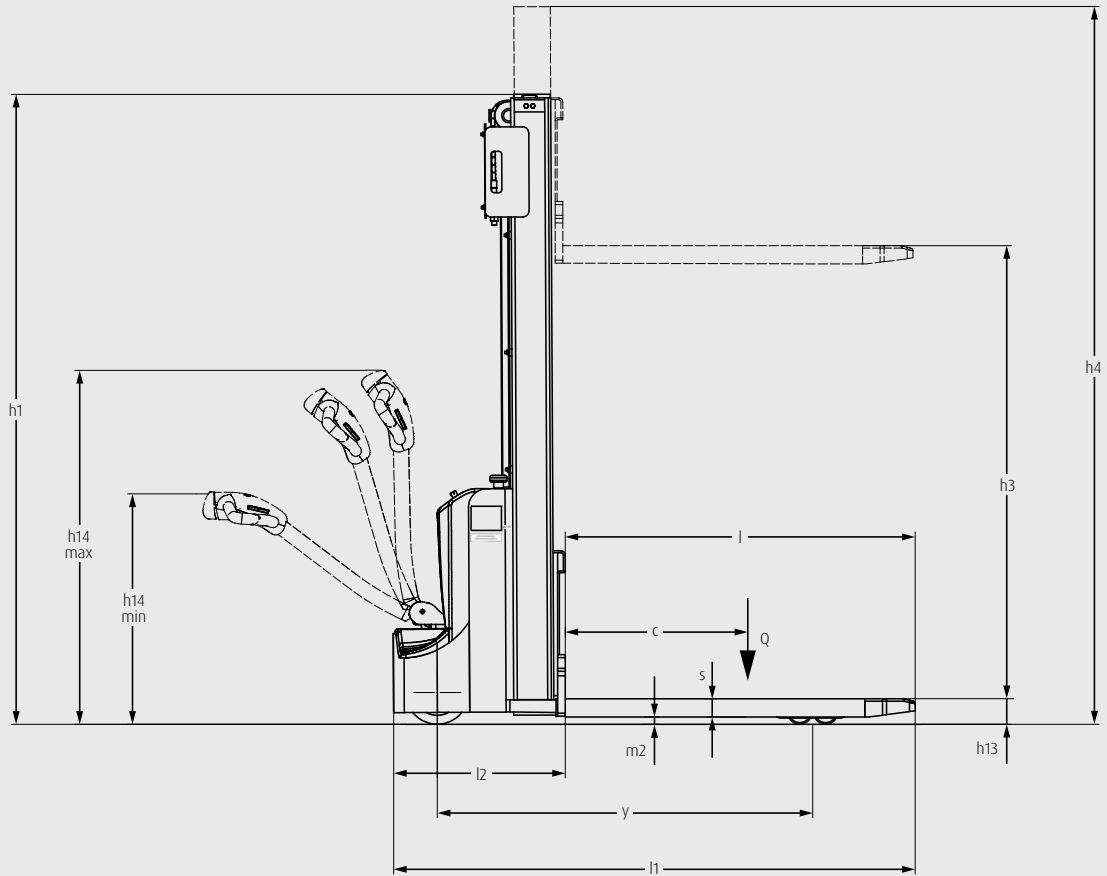

MAST TABLES

MONO MAST (in mm)

Lift	h3: 1517	h3: 1867	h3: 1513	h3: 1863
Height measurements	h1: 1940 h2: 1505 h4: 1955 h3+h13: 1605	h1: 2290 h2: 1855 h4: 2305 h3+h13: 1955	h1: 1940 h2: 1480 h4: 2011 h3+h13: 1608	h1: 2290 h2: 1830 h4: 2361 h3+h13: 1958
Manufacturer's type designation				
MM10	○	○	—	—
MM10i	—	—	○	○

STANDARD MAST (in mm)

Lift	h3: 2427	h3: 2627	h3: 2927	h3: 3227
Height measurements	h1: 1847 h2: 0 h4: 2987 h3+h13: 2515	h1: 1947 h2: 0 h4: 3187 h3+h13: 2715	h1: 2097 h2: 0 h4: 3487 h3+h13: 3015	h1: 2247 h2: 0 h4: 3787 h3+h13: 3315
Manufacturer's type designation				
ML10	○	○	○	○

○ Optional equipment — Not available

h1: Mast height, lowered

h2: Free lift

h3: Lift

h4: Mast height, extended

h3+h13: Lift + fork height

STANDARD AND OPTIONAL EQUIPMENT

Manufacturer's type designation/equipment		MM10	MM10i	ML10
Safety	Height-dependent lifting speed	●	●	●
	Safety reversing button on tiller head	●	●	●
	Automatic parking brake	●	●	●
Service	Maintenance-free AC drive motor	●	●	●
Operation/ load handling	Mechanical steering	●	●	●
	Creep speed	●	●	●
	Initial lift	–	●	–
	4.5 km/h travel speed	●	●	●
Workplace	Display with operating hours counter	●	●	●
	Key switch	●	●	●
Mast	Mono mast	●	●	–
	Standard mast	–	–	●
	Various mast lift heights	○	○	○
Attachment/ forks	Fork length and width across : 1150 × 550 mm	●	–	–
	Fork length and width across : 1150 × 560 mm	–	●	–
	Fork length and width across : 1150 × 570 mm	–	–	●
Axles and tyres	Polyurethane drive wheel	●	●	●
	Tandem polyurethane load wheels	●	●	●
Drive and brake system	Electromagnetic brake	●	●	●
	0.65 kW AC drive motor	●	●	●
Energy	AMG battery 24 V/125 Ah	–	–	●
	AMG battery 24 V/85 Ah	●	●	–
	On-board charger	●	●	●
	UK charger plug	○	○	○
	Plug lock	○	○	○

● Standard equipment ○ Optional equipment – Not available

CHARACTERISTICS



Long tiller arm and emergency stop switch

Safety

- Traction speed automatically reduced when forks are more than 400 mm from the floor
- Long tiller arm ensures operator is always a safe distance from the truck
- Wrap-around tiller head design protects operator's hands
- Parking brake for safe operation on ramps and gradients
- Emergency isolator button cuts power to the truck



Ergonomic tiller handle with integrated drive and lift control

Ergonomics

- Adjustable picking height avoids back strain
- Ergonomic tiller handle allows control of all functions with either hand
- Convenient operation of all controls with either hand
- Precise manoeuvres in confined spaces thanks to creep speed button



Robust chassis and initial lift (optional)

Handling

- Powerful electric motors provide speeds of up to 4.5 km/h
- Robust chassis and reinforced forks for loads up to 1000 kg
- On-board charger allows charging at any suitable socket
- Up to three hours of non-stop operation for maximum productivity
- Initial lift (model MM10i) increases ground clearance aiding operation on ramps



Easy access to all main components

Service

- Easy access to major components for fast, efficient servicing
- Robust traction motor reduces maintenance costs
- Maintenance-free battery maximises up-time and reduces cost
- Automatic discharge protection ensures long battery life

Presented by:

Subject to modification in the interest of progress. Illustrations and technical specifications could include options and are not binding for actual constructions. All dimensions subject to usual tolerances.



Linde Material Handling GmbH
Carl-von-Linde-Platz | 63743 Aschaffenburg | Germany
Phone: + 49 6021 99 0 | Fax + 49 6021 99 1570
www.linde-mh.com | info@linde-mh.com

DS_MM10_ML10_1167_en_B_0924